

THIS DOCUMENT AND THE INFORMATION IT CONTAINS IS THE PROPERTY OF EMTED INC. AND MAY NOT BE USED IN ANY WAY WITHOUT THE EXPRESS WRITTEN CONSENT OF EMTED INC.

REV	REVISION	DATE	ER #	INTL
D1	UPDATED INSTRUCTION, CHART	10/09/2006	5704	LRL
E	UPDATED PART NUMBERS IN INSRUCTIONS	02/01/2007	6454	CCE

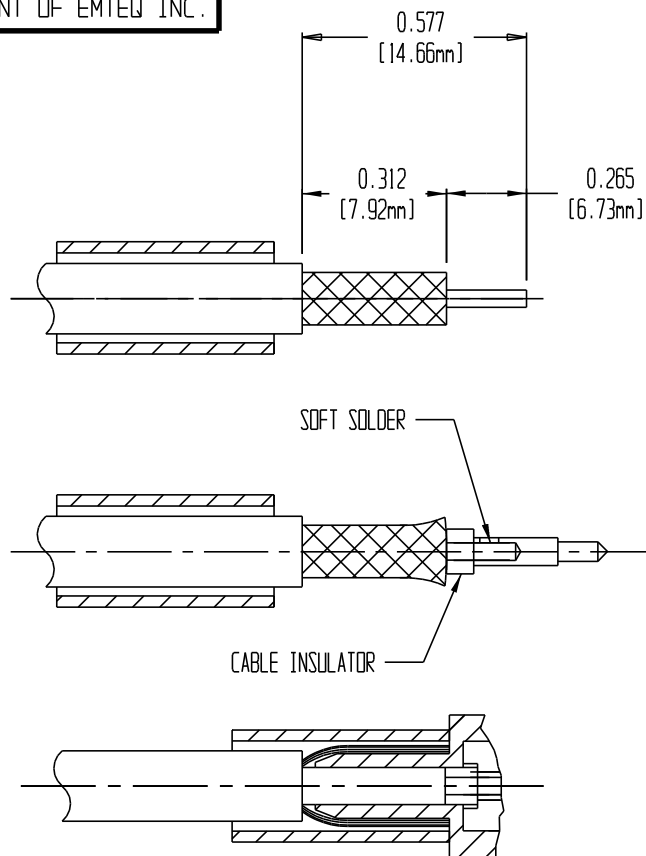

ES-105-1 CABLE ASSEMBLY INSTRUCTIONS

- 1.) SLIDE ON ANY HEAT SHRINK LABELS IF USED, THEN THE BLACK ADHESIVE HEAT SHRINK AND THEN THE CRIMP TUBE.
- 2.) STRIP THE CABLE PER THE DIMENSIONS SHOWN. REMOVE THE MATERIALS.
- 3.) INSTALL THE CABLE INSULATOR ONTO THE CENTER CONDUCTOR BUTTING IT UP AGAINST THE CABLE DIELECTRIC.
- 4.) TIN THE CENTER CONDUCTOR, THEN SOLDER THE CONTACT ONTO THE CENTER CONDUCTOR, BUTTING THE CONTACT UP AGAINST THE CABLE INSULATOR, LEAVING NO GAPS. CAUTION: DO NOT OVERHEAT THE CONTACT AND SWELL THE DIELECTRIC AND/OR INSULATOR. SEE CHART FOR RECOMMENDED SOLDER TEMPERATURES.
- 5.) FLARE THE OUTER SHIELD BRAID BY GENTLY ROTATING THE CONTACT AND DIELECTRIC, THEN FINISH TO FLARE OUT, NOT DISTURBING THE INNER FOIL SHIELD. DO NOT REMOVE THE ALUMINUM MYLAR FOIL INNER SHIELD FROM THE DIELECTRIC.
- 6.) INSERT THE CONTACT INTO THE REAR OF THE CONNECTOR BODY, THE INNER SHIELD BEING INSIDE OF THE CONNECTOR BODY AND THE BRAID SHIELD OUTSIDE, UNTIL THE CONTACT SNAPS INTO PLACE. SLIDE THE CRIMP TUBE UP OVER THE BRAID AND UP AGAINST THE CONNECTOR BODY. CRIMP USING M22520/5-01 (HX4) CRIMPING TOOL WITH APPROPRIATE DIE. SEE CHART.
- 7.) SLIDE BLACK ADHESIVE HEAT SHRINK UP OVER REAR END OF CONNECTOR BODY (EXCLUDING ARINC CONNECTOR'S) AND HEAT SHRINK. FOR ARINC CONNECTOR'S, SLIDE UP TO REAR OF CONNECTOR BODY AND HEAT SHRINK.

* NOTE: WHEN TERMINATING RG-142, RG400, FLX140-500, OR PFLX200-XXX, USE THE GOLD CRIMP TUBE SUPPLIED. WHEN TERMINATING PFLX195-500, OR TFLX130-100, USE THE SILVER CRIMP TUBE SUPPLIED.

CABLE TYPE	MIL-SPEC HEX DIE P/N	DANIELS HEX DIE P/N	HEX SIDE	SOLDER TEMPERATURE
PFLX175-075-XX	M22520/5-43	Y141	B	700-750 ° F (371-398 ° C)
RG-142 B/U	M22520/5-19	Y142	B	700-750 ° F (371-398 ° C)
PFLX140-XXX	M22520/5-41	Y140	B	700-750 ° F (371-398 ° C)
PFLX195-XXX	M22520/5-19	Y142	B	700-750 ° F (371-398 ° C)
PFLX200-XXX	M22520/5-19	Y142	B	700-750 ° F (371-398 ° C)
PFLX240-XXX	M22520/5-43	Y141	A	700-750 ° F (371-398 ° C)
PFLX340-XXX	M22520/5-35	Y137	A	750-800 ° F (398-427 ° C)
PFLX400-XXX	M22520/5-61	Y178	A	800-850 ° F (427-454 ° C)
PFLX500-XXX	M22520/5-21	Y149	A	800-850 ° F (427-454 ° C)
TFLX125-075-XX	M22520/5-41	Y140	B	700-750 ° F (371-398 ° C)
TFLX130-XXX	M22520/5-41	Y140	B	700-750 ° F (371-398 ° C)
TFLX165-XXX	M22520/5-19	Y142	B	700-750 ° F (371-398 ° C)
TFLX205-XXX	M22520/5-43	Y141	A	700-750 ° F (371-398 ° C)
TFLX225-XXX	M22520/5-43	Y141	A	700-750 ° F (371-398 ° C)
TFLX295-XXX	M22520/5-35	Y137	A	750-800 ° F (398-427 ° C)
TFLX480-XXX	M22520/5-27	Y151	A	800-850 ° F (427-454 ° C)

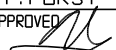
DATE 03/26/2001	 5349 S. EMMER DRIVE NEW BERLIN, WI 53151 (888) 679-6170	
DRAWN A. SWENSON		
DESIGNED		
CHECKED T. FORST 02/01/2007	CABLE STRIPPING INSTRUCTIONS	
APPROVED  02/01/2007		
CAGE CODE 06WH3	DWG # ES-105-1	SHT 1 OF 1

FILE: ES-105-1.prt